

that compounds with branched chains are also present along with the linear fluorocarbons. Nevertheless, with an ionizing energy of 16 e.v., ions of the type C_nF_{n+2} which have to have two CF_2 end groups are not observed in abundance, with the exception of tetrafluoroethylene and perfluorobutadiene, indicating that branched-chain fluorocarbons are not present in the mixture to any appreciable extent. Perfluorocycloparaffins and perfluorocycloolefins both seem to be absent since ions of the type C_nF_{2n} and C_nF_n are not observed at low ionizing voltages. Thus the mass spectra for the decomposition products from poly(carbon monofluoride) apparently arise from perfluoroparaffins of formula C_nF_{2n+2} which give rise to low molecular weight fragments, tetrafluoroethylene, and the various types of polyunsaturated compounds containing three or more C atoms with the formulas C_nF_{n+4} and C_nF_{n+6} , etc., for even-C molecules and C_nF_{n+3} , C_nF_{n+5} , C_nF_{n+7} , etc., for odd-C molecules.

On structural grounds $[(CF)_n]$ and by analogy to the thermal depolymerization of Teflon^{11,12} $[(CF_2)_n]$, one might expect the formation of difluoroacetylene ($CF\equiv CF$), in the thermal decomposition of poly(carbon monofluoride). Although a small ion peak for C_2F_2 at an ionizing energy of 70 e.v. is observed, it must be attributed to fragmentation of higher molecular weight compounds, since it disappears at the lower energies of 25 and 15 e.v.

Acknowledgments.—This research was performed under United States Air Force Contract No. AF 33(615)-1138, through funds administered by Wright-Patterson Air Force Base. The authors are pleased to acknowledge the aid of Dr. T. C. Ehlert in initial stages of this work and helpful conversations with Drs. R. A. Kent and P. L. Timms.

- (11) E. E. Lewis and M. A. Naylor, *J. Am. Chem. Soc.*, **69**, 1968 (1947).
 (12) R. E. Florin, L. A. Wall, D. W. Brown, L. A. Hymo, and J. D. Michaelsen, *J. Res. Natl. Bur. Std.*, **53**, 121 (1954).

CONTRIBUTION FROM THE DEPARTMENT OF CHEMISTRY,
 McMASTER UNIVERSITY, HAMILTON, ONTARIO

The Fluorosulfuric Acid Solvent System. II.¹ Solutions of Antimony Pentafluoride, Antimony Tetrafluoride Monofluorosulfate, and Antimony Pentafluoride-Sulfur Trioxide Mixtures

By R. C. THOMPSON, J. BARR, R. J. GILLESPIE, J. B. MILNE, AND R. A. ROTHENBURY

Received April 2, 1965

Conductometric, cryoscopic, and nuclear magnetic resonance studies on solutions of SbF_5 , SbF_4SO_3F , and SbF_5-SO_3 mixtures in fluorosulfuric acid show that there exists a series of acids with the general formula $H[SbF_{5-n}(SO_3F)_{1+n}]$ where $n = 0, 1, 2$, and 3 which increase in strength with increasing values of n . The acid $H[SbF_2(SO_3F)_3]$ is a strong acid of the fluorosulfuric acid solvent system. Dimeric and probably higher polymeric forms of these acids are also present in the solutions and n.m.r. studies show that polymerization occurs through fluorosulfate bridges. The fluorosulfuric acidium ion, $H_2SO_3F^+$, has been shown to have an abnormally high conductivity in this solvent and it is concluded that it conducts by proton transfer.

Introduction

Woolf² found that antimony pentafluoride gives conducting solutions in fluorosulfuric acid which can be titrated with the strong base potassium fluorosulfate, indicating that SbF_5 behaves as an acid; however, he determined neither the mode nor the degree of ionization. This paper describes conductometric, cryoscopic, and nuclear magnetic resonance studies on solutions of SbF_5 , $SbF_4(SO_3F)$, and SbF_5-SO_3 mixtures in fluorosulfuric acid.

Experimental

Electrical Conductivity Measurements.—The apparatus used for the conductivity measurements has been described previously.¹ Additions of antimony pentafluoride and sulfur trioxide were made to the conductivity cell in the form of concen-

trated solutions in fluorosulfuric acid. All the measurements were made at 25°.

¹⁹F Nuclear Magnetic Resonance.—The n.m.r. measurements were made with a Varian Associates HR 60 spectrometer operating at 56.4 Mc./sec. and equipped with a variable temperature accessory. Temperatures were measured with a copper-constantan thermocouple and a Leeds and Northrup temperature potentiometer. The spectra were calibrated by the side-band technique using a Muirhead-Wigan D-890-A decade oscillator. Solutions were prepared in tubes made from selected 5-mm. glass tubing. The components were introduced by means of capillary droppers, and the tubes then were sealed off.

Cryoscopic Measurements.—The apparatus and experimental technique are described in part III.³

Materials.—Fluorosulfuric acid and potassium fluorosulfate were purified as described previously.¹ Commercial antimony pentafluoride was triple distilled in an all-glass apparatus in an atmosphere of dry air (b.p. 142–143°). Sulfur trioxide was distilled from 30 or 65% oleum to which potassium persulfate had

(1) Part I: J. Barr, R. J. Gillespie, and R. C. Thompson, *Inorg. Chem.*, **3**, 1149 (1964).

(2) A. A. Woolf, *J. Chem. Soc.*, 433 (1955).

(3) Part III: R. J. Gillespie, J. B. Milne, and R. C. Thompson, *Inorg. Chem.*, to be published.

been added to oxidize any sulfur dioxide impurity. Antimony tetrafluoride monofluorosulfate was prepared as described previously.⁴

Results and Discussion

Conductivity Measurements.—Conductivity data for solutions of SbF_5 are given in Table I and Figure 1. The results of experiments in which sulfur trioxide was added to an SbF_5 solution are also given in Table I. The reaction between SO_3 and SbF_5 is rather

TABLE I
SPECIFIC CONDUCTANCES AT 25°

SbF_5				$\text{SbF}_5\text{-SO}_3$		
10^2m	$10^4\kappa$, $\text{ohm}^{-1}\text{cm.}^{-1}$	10^2m	$10^4\kappa$, $\text{ohm}^{-1}\text{cm.}^{-1}$	10^2m SbF_5	Mole ratio SO_3/SbF_5	$10^4\kappa$, $\text{ohm}^{-1}\text{cm.}^{-1}$
0.835	14.44	0.176	3.37	2.59	0.000	25.88
1.662	21.12	0.386	7.31	2.58	2.370	61.07
2.594	25.88	0.753	11.84	2.57	2.644	62.85
2.778	28.36	1.514	18.25	2.56	3.424	65.27
3.932	35.02	3.946	32.04	2.56	3.696	65.62
4.030	35.16	4.882	38.33	2.56	4.174	66.05
4.313	37.75	6.027	43.51	6.45	1.627	104.9
6.918	48.45	8.041	51.95	6.43	2.006	122.3
9.859	61.14	10.49	61.42	6.39	3.000	147.0
10.91	65.29	13.88	72.75	6.37	3.267	149.7
11.69	70.04	14.51	75.65	6.33	4.157	152.4
12.41	70.93	21.37	96.93	6.28	5.380	151.2
15.29	81.49	21.98	100.2	11.7	2.804	237.7
15.45	82.06	34.08	135.9	11.6	3.384	250.1
17.84	90.69	48.82	174.9	11.5	4.132	253.2
18.79	93.66	59.58	199.7	11.4	5.018	253.2
		73.08	228.9	3.86	6.15	106.4
				6.85	6.26	174.4
				8.54	6.28	207.2
				16.76	3.21	340.6

slow and after each addition of SO_3 3–4 hr. was required before equilibrium was attained. Although sulfur trioxide is a nonelectrolyte in fluorosulfuric acid,³ when it is added to a solution of antimony pentafluoride it increases the conductivity until a mole ratio SO_3/SbF_5 of 3 to 4 is reached after which further addition of sulfur trioxide causes no further increase in the conductivity. In order to account for these results we assume that SbF_5 is a rather weak acid ionizing according to the equation

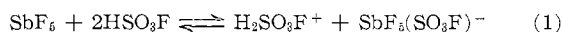

and that sulfur trioxide reacts with antimony pentafluoride to give the fluorosulfates $\text{SbF}_4(\text{SO}_3\text{F})$, $\text{SbF}_3(\text{SO}_3\text{F})_2$, and $\text{SbF}_2(\text{SO}_3\text{F})_3$ which become increasingly strong acids with increasing number of fluorosulfate groups

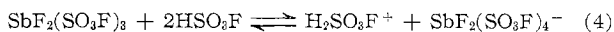
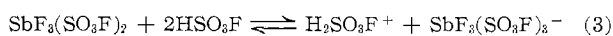
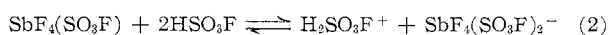

The higher fluorosulfates $\text{SbF}(\text{SO}_3\text{F})_4$ and $\text{Sb}(\text{SO}_3\text{F})_5$ may also exist but the conductivity results do not give any evidence for them. If they do exist they are not appreciably stronger acids than $\text{SbF}_2(\text{SO}_3\text{F})_3$. The small increase in conductivity as the mole ratio $\text{SO}_3/$

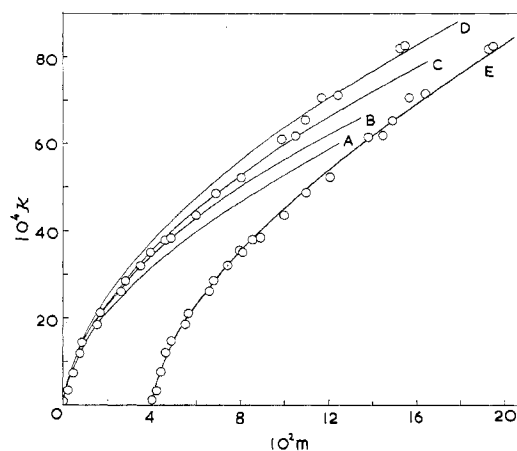

Figure 1.—Conductivities of solutions of antimony pentafluoride: A, B, C, D, and E are calculated curves (see text), E has been displaced horizontally by 4 units.

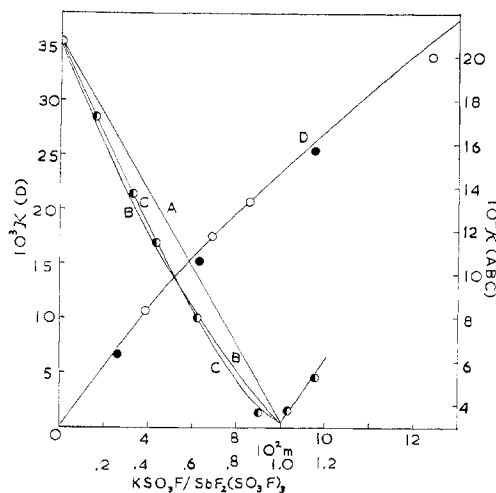

Figure 2.—Conductivities of solutions of $\text{H}[\text{SbF}_2(\text{SO}_3\text{F})_4]$, *i.e.*, solutions of SbF_5 containing SO_3 in excess of the mole ratio $\text{SO}_3/\text{SbF}_5 = 3$, and a conductometric titration with KSO_3F : A, B, C, D are calculated curves (see text); \circ , experimental conductivities; \bullet , titration.

SbF_5 is increased from 3 to 4 does not necessarily have to be attributed to the formation of $\text{SbF}(\text{SO}_3\text{F})_4$. N.m.r. measurements described later show that $\text{SbF}_2(\text{SO}_3\text{F})_3$ is appreciably dissociated according to the equation



and the conductivity increase can reasonably be attributed to repression of this equilibrium by excess SO_3 . The monofluorosulfate $\text{SbF}_4(\text{SO}_3\text{F})$ has been prepared previously by direct reaction between SO_3 and SbF_5 in the absence of any solvent.⁴ The conductivities of solutions having the composition $\text{SO}_3/\text{SbF}_5 > 3$ are shown in Figure 2. They fall on a reasonably smooth curve and this is taken to represent the conductivity-concentration curve of the acid $\text{SbF}_2(\text{SO}_3\text{F})_3$. A conductometric titration with KSO_3F was carried out on one of these solutions and the results are given in Table II and Figure 2. A minimum conductivity was obtained at the mole ratio $\text{KSO}_3\text{F}/\text{SbF}_2(\text{SO}_3\text{F})_3 = 1.0$,

(4) R. J. Gillespie and R. A. Rothenbury, *Can. J. Chem.*, **42**, 416 (1964).

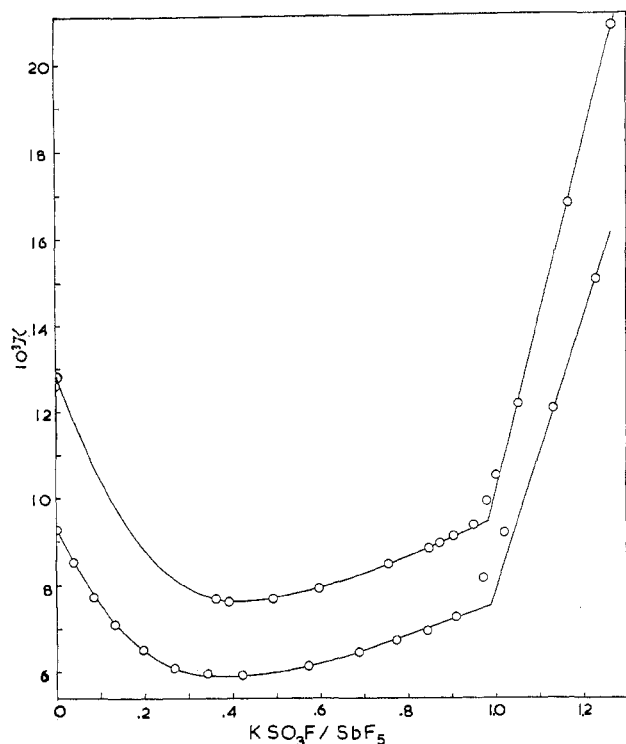

Figure 3.—Conductometric titrations of $\text{H}[\text{SbF}_5(\text{SO}_3\text{F})]$ with KSO_3F .

TABLE II

CONDUCTOMETRIC TITRATIONS OF $\text{HSbF}_5(\text{SO}_3\text{F})$ AND $\text{HSbF}_2(\text{SO}_3\text{F})_4$

Mole ratio $\text{KSO}_3\text{F}/\text{acid}$	$10^4\kappa$, $\text{ohm}^{-1} \text{cm.}^{-1}$	Mole ratio $\text{KSO}_3\text{F}/\text{acid}$	$10^4\kappa$, $\text{ohm}^{-1} \text{cm.}^{-1}$
$\text{HSbF}_5(\text{SO}_3\text{F})$ (0.188 <i>m</i>)		$\text{HSbF}_5(\text{SO}_3\text{F})$ (0.311 <i>m</i>)	
0.0000	93.66	0.0000	127.18
0.0349	86.09	0.3571	77.39
0.0810	78.03	0.3861	77.09
0.1277	71.83	0.4843	77.55
0.1913	65.98	0.5924	79.99
0.2614	62.15	0.7493	85.43
0.3400	60.16	0.8405	89.10
0.4158	59.87	0.8667	90.30
0.5649	61.99	0.8984	91.28
0.6789	65.03	0.9427	94.70
0.7673	67.83	0.9725	100.1
0.8368	70.29	0.4930	106.0
0.9021	73.38	1.043	122.3
0.9650	82.48	1.164	168.8
1.0115	92.76	1.270	209.7
1.1218	121.39	$\text{HSbF}_2(\text{SO}_3\text{F})_4$ (0.0854 <i>m</i>)	
1.2255	151.33	0.0000	207.2
		0.1569	172.5
		0.3224	137.1
		0.4344	114.1
		0.6175	80.16
		0.9013	35.77
		1.0306	37.54
		1.1488	52.65
		1.3240	75.59

showing that $\text{SbF}_2(\text{SO}_3\text{F})_3$ is a strong acid. Conductometric titrations of solutions of SbF_5 with KSO_3F gave minimum conductivities at $\text{KSO}_3\text{F}/\text{SbF}_5 \sim 0.4$, showing that SbF_5 is indeed a weak acid (Table II and Figure 3). The equivalence point in the SbF_5 - KSO_3F titrations was found at $\text{KSO}_3\text{F}/\text{SbF}_5 = 0.97$ instead of the

expected value of 1.00. This can probably be attributed to the fact that a rather large number of additions of KSO_3F were made during these titrations and hence a small amount of water vapor may have entered the cell neutralizing some of the acid. The n.m.r. evidence presented later shows that these acids exist in the solvated form $\text{HSbF}_{5-n}(\text{SO}_3\text{F})_{n+1}$ and their ionization may therefore be represented by the equation

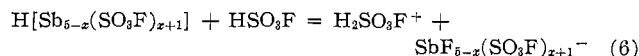

The quantitative treatment of the conductivity results is greatly simplified if it is assumed that the conductivities of solutions of strong electrolytes vary linearly with concentration. Thus we define a quantity $\lambda^* = 1000\kappa_{\text{ion}}/m$, where κ_{ion} is the specific conductance ($\text{ohm}^{-1} \text{cm.}^{-1}$) of an individual ion at a concentration m (moles kg.^{-1}). We may note that for potassium fluorosulfate¹ the ratio κ/m decreases by only $\sim 8\%$ from 0.01 to 0.1 *m*. For any solution then, the conductivity is given to a good approximation by the expression

$$\kappa = 10^{-3} \sum_n \lambda_n^* m_n \quad (7)$$

Conductometric titration curves for the titration of $\text{SbF}_2(\text{SO}_3\text{F})_3$ with KSO_3F calculated by means of eq. 7 and using various values for the acid dissociation constant K_1 of $\text{SbF}_2(\text{SO}_3\text{F})_3$, *i.e.*, $\text{H}[\text{SbF}_2(\text{SO}_3\text{F})_4]$, are shown in Figure 2. The required values of λ^* for the ions $\text{SbF}_2(\text{SO}_3\text{F})_4^-$, K^+ , and $\text{H}_2\text{SO}_3\text{F}^+$ were obtained as follows. At the equivalence point of the titration in Figure 2, 0.0854 *m* K^+ and 0.0854 *m* $\text{SbF}_2(\text{SO}_3\text{F})_4^-$ give a total conductivity of $32.0 \times 10^{-4} \text{ohm}^{-1} \text{cm.}^{-1}$. From the conductivity and transport number results reported in part I¹ we find that a 0.0854 *m* solution of K^+ has a conductivity of $21 \times 10^{-4} \text{ohm}^{-1} \text{cm.}^{-1}$; hence $\lambda_{\text{K}^+}^* = 25$ and $\lambda_{\text{SbF}_2(\text{SO}_3\text{F})_4^-}^* = 13$. The conductivity of a 0.0854 *m* solution of $\text{H}[\text{SbF}_2(\text{SO}_3\text{F})_4]$ is $207.2 \times 10^{-4} \text{ohm}^{-1} \text{cm.}^{-1}$. It is assumed this conductivity arises from a 0.0854 *m* concentration of the ions $\text{SbF}_2(\text{SO}_3\text{F})_4^-$ and $\text{H}_2\text{SO}_3\text{F}^+$; hence $\lambda_{\text{H}_2\text{SO}_3\text{F}^+}^* = 230$. The titration curve A in Figure 2 was then calculated using the above λ^* values and $K_1 = \infty$. The experimental points deviate considerably from this curve. Rather better agreement with experiment can be obtained by assuming that the acid is not completely strong. The best fit with the experimental results was obtained by assuming $10^2 K_1 = 4$ (curve B in Figure 2). Although the agreement between the experimental points and curve B is reasonable, in view of the strong tendency of both SbF_5 and $\text{SbF}_4(\text{SO}_3\text{F})$ to polymerize,^{4,5} we calculated the effect of dimer formation on the conductivity curves. We assume that both $\text{H}[\text{SbF}_2(\text{SO}_3\text{F})_4]$ and the dimeric acid $\text{H}\{[\text{SbF}_2(\text{SO}_3\text{F})_3]_2\text{SO}_3\text{F}\}$ are strong acids

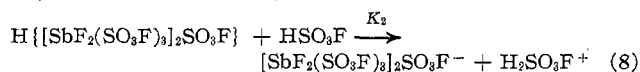

(5) C. J. Hoffman, B. E. Holder, and W. L. Jolly, *J. Phys. Chem.*, **62**, 364 (1958).

i.e., $K_1 = K_2 = \infty$. The concentration of $\text{H}_2\text{SO}_3\text{F}^+$ then depends on the relative amounts of monomer and dimer, *i.e.*, on the equilibrium

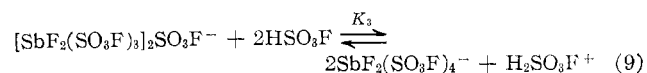

This postulate was tested by assigning arbitrary values to K_3 , the equilibrium constant for (9), calculating $\lambda^*_{\text{H}_2\text{SO}_3\text{F}^+}$, and thus obtaining theoretical titration curves. The best fit with the experimental results was obtained for $10^3K_3 = 4$ and $\lambda^*_{\text{H}_2\text{SO}_3\text{F}^+} = 320$ (curve C in Figure 2). In these calculations it was assumed that the mobility of the dimeric anion is equal to that of the monomeric anion. This approximation is quite adequate as in all the cases considered the dimeric anion accounted for only a very small part of the total conductivity.

As a check on the validity of the above conclusions a theoretical conductivity-concentration plot for $\text{SbF}_2(\text{SO}_3\text{F})_3$ was calculated on the basis of $K_3 = 4 \times 10^{-3}$ and the λ^* values determined from the conductometric titration data. This is curve D in Figure 2. The agreement between the calculated curve and the experimental points is good. The experimental point at the highest concentration is low because SO_3 was not present in sufficient excess to shift equilibrium 5 completely to the left. The points denoted by solid circles are probably also low because they were obtained from experiments in which a number of successive additions of SO_3 were made to a solution of SbF_3 and there is the possibility that small amounts of water vapor entered the cell during these additions and thus partly neutralized the acid $\text{H}[\text{SbF}_2(\text{SO}_3\text{F})_4]$. We conclude that the ionization of $\text{H}[\text{SbF}_2(\text{SO}_3\text{F})_4]$ is best described in terms of eq. 6, 8, and 9 with $K_1 = K_2 = \infty$ and $K_3 = 4 \times 10^{-3}$.

The conductivity data for antimony pentafluoride were treated in a manner similar to that described above. Assuming ionization according to eq. 10

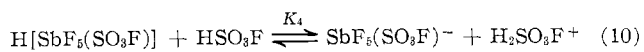

arbitrary values were assigned to the equilibrium constant K_4 and the theoretical conductivity curves A, B, C, and D were obtained (Figure 1), corresponding to $10^3K_4 = 3.0, 3.5, 4.0,$ and 4.5 , respectively. None of the calculated curves agrees with experiment over the whole concentration range, although B and C agree reasonably well at low concentrations. The best value for 10^3K_4 at low concentrations was taken as 3.7. Although one would not expect equilibrium constants based on concentrations instead of activities to describe accurately the behavior of a partially dissociated acid over a large concentration range, the values of the concentration equilibrium constants for weak bases in fluorosulfuric acid change by only a few per cent over the reasonably large concentration range studied.¹ One might therefore expect a similar change in K_4 , but in order to obtain agreement with experiment K_4 would have to increase by 40% over the range 0.05–0.2 *m*.

It appears that SbF_5 becomes relatively more ionized as its concentration is increased, contrary to normal behavior for weak electrolytes. Aqueous solutions of HF exhibit a similar behavior⁶; in dilute solutions HF is a weak acid while in more concentrated solutions the acidity increases due to the formation of strongly polymeric acids $(\text{HF})_n$. The behavior of SbF_5 in fluorosulfuric acid may be explained in an analogous manner. It is assumed that dimerization occurs and that the two equilibria involved are represented by eq. 10 ($K_4 = 3.7 \times 10^{-3}$) and by eq. 11. A value of 7 for 10^3K_5

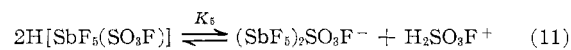

gives the calculated conductivity curve E, which agrees well with experiment. The required λ^* values were obtained as described above. A value of 13 for $\lambda^*_{\text{SbF}_5\text{SO}_3\text{F}^-}$ was determined from the conductivity at the equivalence point of the conductometric titration curve of SbF_5 with KSO_3F for $(\text{SbF}_5) = 0.188 \text{ m}$ (Figure 3). A smaller value was calculated from the equivalence point for the titration of the 0.311 *m* SbF_5 solution, but since the above value is the same as that obtained for $\text{SbF}_2(\text{SO}_3\text{F})_4^-$ and as the calculated conductivity curves refer to concentrations $< 0.2 \text{ m}$ it seems reasonable to use the higher value. In any case the calculated curves are not very sensitive to this value. As $\text{H}[\text{SbF}_5(\text{SO}_3\text{F})]$ is not a strong acid allowance should be made for solvolysis of the ion $\text{SbF}_5\text{SO}_3\text{F}^-$. However, calculation shows that the concentration of SO_3F^- produced in this manner is extremely small solvolysis of 0.188 *m* $\text{SbF}_5\text{SO}_3\text{F}^-$ producing approximately 0.0008 *m* SO_3F^- . Hence, allowing for solvolysis only affected $\lambda^*_{\text{SbF}_5\text{SO}_3\text{F}^-}$ and the calculated conductivity curves shown in Figure 1 to a negligible extent. It was assumed that $\lambda^*_{(\text{SbF}_5)_2\text{SO}_3\text{F}^-} = \lambda^*_{\text{SbF}_5\text{SO}_3\text{F}^-}$ and that $\lambda^*_{\text{H}_2\text{SO}_3\text{F}^+} = 320$. Since the ionic strength of the SbF_5 solutions is not constant over the range studied, the approximation that λ^* is independent of concentration is not as good as it is for the strong acid $\text{HSbF}_2(\text{SO}_3\text{F})_4$, for which the titration involves simply the replacement of $\text{H}_2\text{SO}_3\text{F}^+$ by K^+ and no change in the total ionic strength. However, making allowance for some decrease in λ^* with increasing concentration only gives poorer agreement between the experimental and theoretical curves in Figure 1.

The behavior of SbF_5 is best described by eq. 10 and 11 with $10^3K_4 = 3.7$ and $10^3K_5 = 7$. Because of the approximations involved in the calculations, these equilibrium constants cannot be regarded as very precise.

Assuming that $\lambda^*_{\text{H}_2\text{SO}_3\text{F}^+} = 320$ at infinite dilution and making use of the value 1.7264 for the density of fluorosulfuric acid,¹ the ionic mobility at infinite dilution, $\lambda_0(\text{H}_2\text{SO}_3\text{F}^+)$, is calculated to be 185. Hence, the mobility of the fluorosulfuric acidium ion is greater than the mobility of the fluorosulfate ion [$\lambda_0(\text{SO}_3\text{F}^-) =$

(6) R. P. Bell, K. N. Bascombe, and J. C. McCoubrey, *J. Chem. Soc.*, 1286 (1956).

TABLE III

Species	Solute	Chemical shifts ^a (p.p.m.) and coupling constants <i>J</i> (c.p.s.)											
		Monomer (D)					Dimer (E)						
		Doublet	Quintet	$\Delta\delta$	<i>J</i>	Doublet	Quintet	$\Delta\delta$	<i>J</i>				
SbF ₅		149.8	179.6	29.8	100	151.3	176.4	25.1	100				
SbF ₅ (SO ₃ F) ⁻	SO ₃ /SbF ₅ = 0.6	152.0	189.5	27.5	103	152.8	104				
	SbF ₄ SO ₃ F	99	98				
		Monomer					Dimer						
		Triplet (G)	Triplet (L)	Singlet (I)	$\Delta\delta_{GP}$	$\Delta\delta_{GI}$	<i>J</i>	Triplet (F)	Triplet (P)	Singlet (H)	$\Delta\delta_{FP}$	$\Delta\delta_{FH}$	<i>J</i>
SbF ₄ (SO ₃ F) ⁻	SbF ₄ SO ₃ F	24.86	4.67	122	25.62	5.07	127
	SO ₃ /SbF ₅ = 0.67	139.6	164.4	159.0	24.89	4.82	126	138.9	164.4	144.1	25.59	5.27	126
	SO ₃ /SbF ₅ = 1.8	...	159.0	139.8	122	...	159.0	139.5	122
		Doublet (N)	Quartet (O)	Singlet (P)	$\Delta\delta_{NO}$	$\Delta\delta_{NP}$	<i>J</i>						
SbF ₃ (SO ₃ F) ₃ ⁻	SO ₃ /SbF ₅ = 1.8	131.3	147.5	144.7	16.2	13.4	126						
	SO ₃ /SbF ₅ = 3.2	134.3	151.3	148.2	17.0	13.9	124						
SbF ₂ (SO ₃ F) ₄ ⁻		Q	R										
	SO ₃ /SbF ₅ = 3.2	130.8	138.1										

^a Measured from the solvent peak.

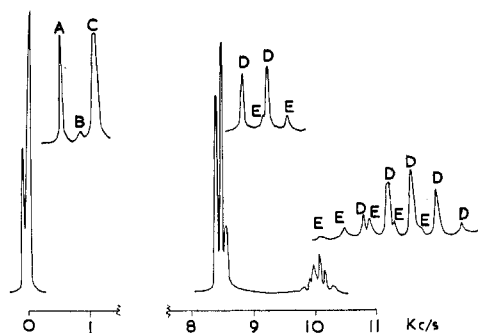

Figure 4.—¹⁹F n.m.r. spectrum of a 1.7 *m* solution of SbF₅ at -67°.

135¹]. Therefore, H₂SO₃F⁺, like SO₃F⁻, very probably conducts by a proton-transfer mechanism.

¹⁹F N.m.r. Spectra.—At 25° the lines in the ¹⁹F n.m.r. spectrum of a solution of SbF₅ in fluorosulfuric acid are very broad, presumably because of exchange processes, but at low temperatures the rates of these exchange processes are very much reduced and each of the broad peaks is resolved into several lines. Figure 4 shows the spectrum of a 1.7 *m* solution of SbF₅ in HSO₃F at -66°. The detailed structure of each peak was obtained by recording these portions of the spectrum at a slow sweep rate. Chemical shifts measured from the solvent peak and fluorine-fluorine coupling constants are recorded in Table III.

The three low-field peaks A, B, and C arise from fluorine bonded to sulfur, C being the solvent peak. The remaining peaks are due to fluorine bonded to antimony; the peaks D constitute an AX₄ spectrum with a chemical shift $\delta_{FF'}$, measured from the center of the doublet to the center of the quintet, of 1662 c.p.s. and a coupling constant $J_{FF'}$ of 100 c.p.s. The peaks E make up another AX₄ spectrum and in this case $\delta_{FF'}$ is 1415 c.p.s. and $J_{FF'}$ is 100 c.p.s. We interpret this spectrum in the following manner. Antimony pentafluoride forms the monosolvated species I having an approximately octahedral arrangement of groups about antimony, and I is partially ionized (eq. 10) to give the

anion SbF₅SO₃F⁻ (II). Rapid proton transfer occurs between I and II since only one proton signal is observed in the ¹H n.m.r. spectrum of this solution, and thus only a combined ¹⁹F n.m.r. signal is expected for these two species. The fluorines designated F³ in I and II thus give rise to peak A in Figure 6, 72 c.p.s. to low field of the solvent peak. Of the fluorine atoms bonded to antimony, four designated F¹ in a plane *cis* to the fluorosulfate group are equivalent to each other and are different from F² which is *trans* to the fluorosulfate group. These five fluorine atoms give rise to the AX₄ spectrum D. The small peak, B, and the AX₄ spectrum, E, can be explained by assuming the formation of the dimeric anion III according to eq. 11, the fluorine atom F⁶ giving rise to peak B and fluorines F⁴ and F⁵ giving the AX₄ spectrum. If 20% of the SbF₅

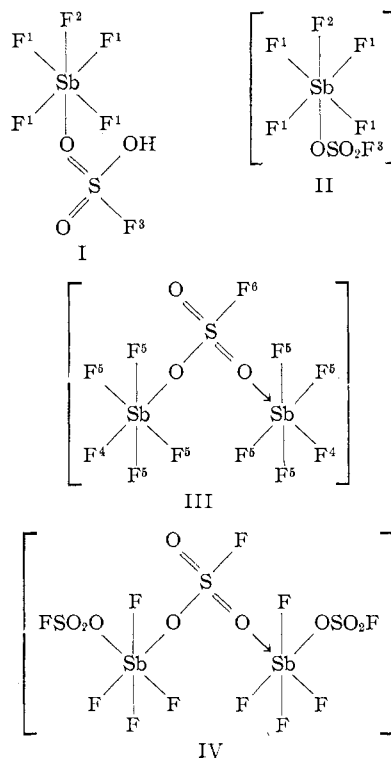

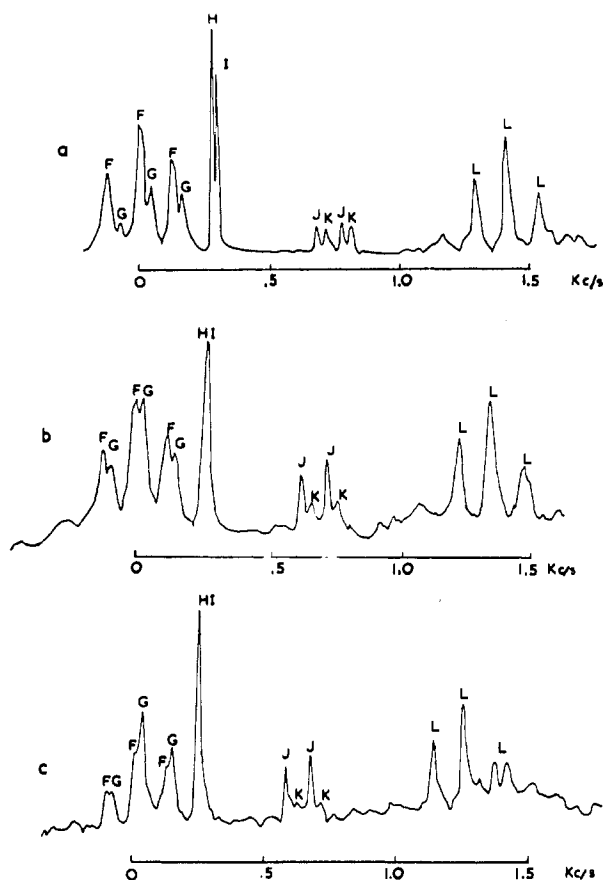

Figure 5.— ^{19}F n.m.r. spectra (F-on-Sb region only) of solutions of $\text{SbF}_4(\text{SO}_3\text{F})$: a, -51° , 3.6 *m*; b, -86° , 1.8 *m*; c, -88° , 1.0 *m*.

is present as dimer and 80% as monomer, then the relative intensities of the peaks are explained. Thus the n.m.r. spectrum lends support to the explanation of the conductivity data given above.

The n.m.r. spectrum of the pure liquid $\text{SbF}_4\text{SO}_3\text{F}$ has been reported previously.⁴ In the fluorine on antimony region the spectrum contains an A_2X_2 pattern (a pair of 1:2:1 triplets) and a single line. This spectrum has been interpreted as indicating that the compound is polymerized by fluorosulfate bridges and that these bridges may be either *cis* or *trans* to each other. The two pairs of nonequivalent fluorines on antimony with *cis* fluorosulfates give rise to the A_2X_2 spectrum and the four equivalent fluorines on antimony with *trans* fluorosulfate groups give rise to the additional single line.

The spectra of three solutions of $\text{SbF}_4\text{SO}_3\text{F}$ in fluoro-sulfuric acid in the fluorine on antimony region are shown in Figure 5. As for the SbF_5 solutions, the spectra obtained at -50° and below contain fine structure which, due to exchange processes, is absent at room temperature. The spectra resemble those obtained for the pure compound⁴ (*i.e.*, in the absence of solvent), except that the low-field triplet is replaced by two partially overlapping triplets F and G, the single peak is replaced by the two peaks H and I, and two new doublets J and K appear. The main features of the spectra are best interpreted by assuming that fluoro-

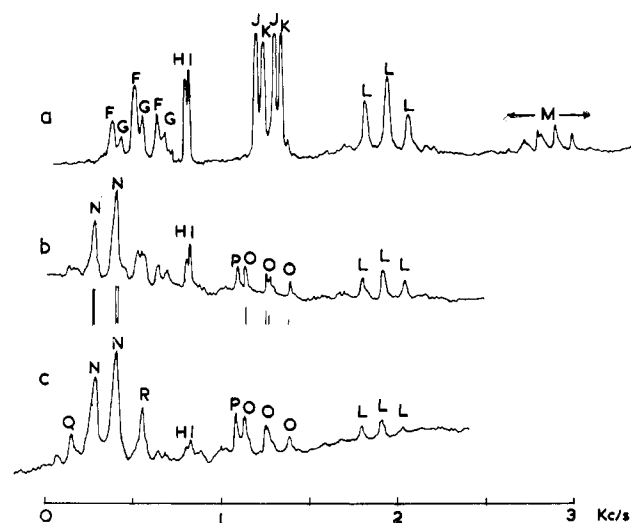

Figure 6.— ^{19}F n.m.r. spectra (F-on-Sb regions only) of solutions of $\text{SbF}_5\text{-SO}_3$: a, -63° , $\text{SO}_3/\text{SbF}_5 = 0.68$, $\text{SbF}_5 = 3.3$ *m*; b, -67° , $\text{SO}_3/\text{SbF}_5 = 1.8$, $\text{SbF}_5 = 2.5$ *m*; c, -71° , $\text{SO}_3/\text{SbF}_5 = 3.2$, $\text{SbF}_5 = 3.3$ *m*.

sulfuric acid breaks down the polymers to give the six-coordinated complex $\text{H}[\text{SbF}_4(\text{SO}_3\text{F})_2]$. Since proton exchange between $\text{H}[\text{SbF}_4(\text{SO}_3\text{F})_2]$ and the solvent appears to be rapid we will, for convenience, write this and related compounds in their anionic form, *e.g.*, $\text{SbF}_4(\text{SO}_3\text{F})_2^-$. This anion may exist in *cis* and *trans* forms which would give rise to a pair of triplets (*i.e.*, an A_2X_2 spectrum) and a single line just as for the compound $\text{SbF}_4\text{SO}_3\text{F}$ in the liquid state. The complexity of the spectrum, however, indicates that other species are present, and since the solutions are relatively concentrated it is not unreasonable to assume that the polymers of the pure substance are not completely broken down in solution and species such as IV and the corresponding *cis-trans* and *trans-trans* isomers and possibly also higher polymers are present. Since the triplet G and the singlet I increase in intensity relative to F and H with increasing dilution (Figure 5), the former may be assigned to the monomeric ions and the latter to the dimeric ions. At high field there should of course be two triplets corresponding to F and G. The fact that only one triplet L is observed can be attributed to the appropriate chemical shifts and coupling constants being such that the two triplets overlap completely. The main peaks in the spectrum can thus be satisfactorily assigned. There remain only the two doublets J and K and a number of small and rather ill-defined peaks mainly in the region of the triplet L. The components of the two doublets J and K have the same separation of 100 c.p.s. as the two doublets obtained in the spectrum of SbF_5 in fluoro-sulfuric acid (Figure 4) which have been attributed to the four equivalent fluorines on each antimony in II and III. The expected quintets due to the single nonequivalent fluorine on each antimony were not observed, probably because they have only one-quarter of the intensity of the corresponding doublet and this intensity is spread over five peaks. The anion $\text{SbF}_5\text{SO}_3\text{F}^-$ is probably produced by reaction 12.

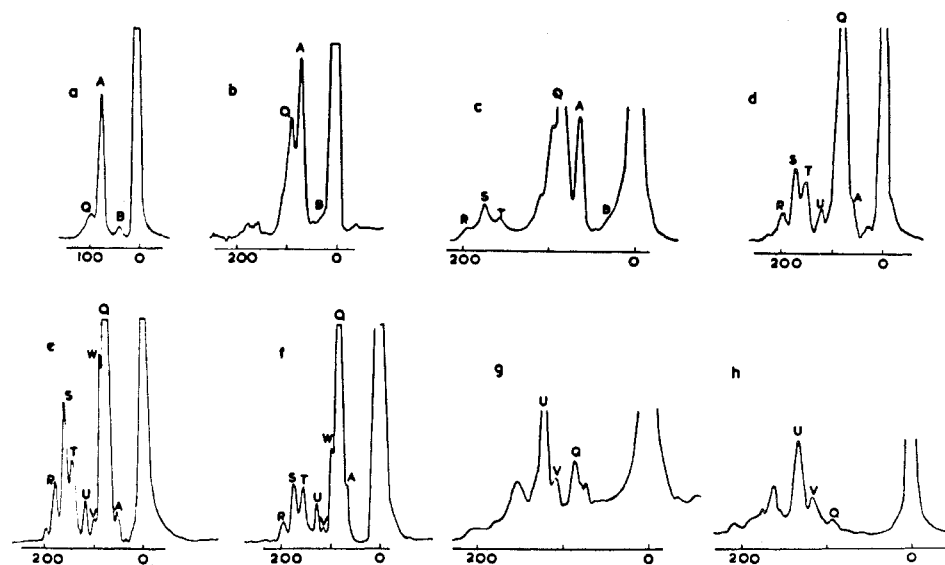

Figure 7.— ^{19}F spectra (F-on-S region only) of solutions of $\text{SbF}_4(\text{SO}_3\text{F})$ and of $\text{SbF}_5\text{-SO}_3$ mixtures: a, -72° , $\text{SO}_3/\text{SbF}_5 = 0.1$, $\text{SbF}_5 = 2.3\text{ m}$; b, -70° , $\text{SO}_3/\text{SbF}_5 = 0.3$, $\text{SbF}_5 = 2.3\text{ m}$; c, -63° , $\text{SO}_3/\text{SbF}_5 = 0.68$, $\text{SbF}_5 = 3.3\text{ m}$; d, -63° , $\text{SO}_3/\text{SbF}_5 = 0.9$, $\text{SbF}_5 = 2.3\text{ m}$; e, -49° , $\text{SbF}_4(\text{SO}_3\text{F}) = 3.6\text{ m}$; f, -50° , $\text{SbF}_4(\text{SO}_3\text{F}) = 1.8\text{ m}$; g, -69° , $\text{SO}_3/\text{SbF}_5 = 1.8$, $\text{SbF}_5 = 2.5\text{ m}$; h, -64° , $\text{SO}_3/\text{SbF}_5 = 3.2$, $\text{SbF}_5 = 3.3\text{ m}$.



The fluorine-on-antimony region of the spectra of three solutions containing sulfur trioxide and antimony pentafluoride are shown in Figure 6, and the chemical shifts and coupling constants obtained from the spectra are given in Table III. Consider first spectrum a. Since the mole ratio of SO_3/SbF_5 is 0.68, it is reasonable to assume that this solution contains a mixture of SbF_5 and $\text{SbF}_4(\text{SO}_3\text{F})$. Peaks J, K, and M constitute two overlapping doublets and quintets. This portion of the spectrum is essentially the same as that of solutions of SbF_5 alone. The chemical shifts between the doublets and quintets are similar and the spin-spin coupling constants are identical (Table III). Therefore peaks J, K, and M may be assigned to I, II, and III. The rest of the spectrum is the same as the spectrum observed for solutions of $\text{SbF}_4(\text{SO}_3\text{F})$ (Figure 5). The peaks F, G, H, I, and L are therefore assigned as before to the *cis* and *trans* forms of $\text{SbF}_4(\text{SO}_3\text{F})_2^-$ and the corresponding dimeric ions such as IV.

The effect of increasing the ratio of sulfur trioxide to antimony pentafluoride may be seen in the spectrum (b) of a solution containing SbF_5 and SO_3 in the mole ratio 1:1.8 (Figure 6). Some of the peaks at low field and the peaks H, I, and L are assigned to the species produced by $\text{SbF}_4(\text{SO}_3\text{F})$. The six peaks N and O are new peaks which do not occur in spectrum a; they are therefore assigned to the species produced in solution by $\text{SbF}_3(\text{SO}_3\text{F})_2$. The six peaks N, O consisting of a doublet N and a "triplet" O are assigned to an AB_2 spectrum with $\delta_{\text{FF}'}/J_{\text{FF}'} = 7.5$. A theoretical AB_2 spectrum for this ratio of chemical shift to coupling constant was calculated,⁷

and it is shown schematically below spectrum b. In order to explain this spectrum we assume that $\text{SbF}_3(\text{SO}_3\text{F})_2$ gives rise to *cis*- and *trans*- $\text{SbF}_3(\text{SO}_3\text{F})_3^-$. All the fluorines bonded to antimony are equivalent in *cis*- $\text{SbF}_3(\text{SO}_3\text{F})_3^-$, so this gives rise to the single peak P, while *trans*- $\text{SbF}_3(\text{SO}_3\text{F})_3^-$ is presumed to give rise to the AB_2 spectrum. Dimeric species analogous to those described previously doubtless exist in this solution, although there is no direct evidence for them. For solutions of antimony pentafluoride, the chemical shift between the peaks due to the monomeric and dimeric species is about 90 c.p.s., and for $\text{H}[\text{SbF}_4(\text{SO}_3\text{F})_2]$ it is only ~ 20 c.p.s. Therefore it is not too surprising that for $\text{H}[\text{SbF}_3(\text{SO}_3\text{F})_3]$ the spectra due to monomeric and dimeric species are not resolvable.

The ^{19}F spectrum (c) for a solution containing antimony pentafluoride and sulfur trioxide in the mole ratio 1:3.2 is also given in Figure 6. Very small peaks H, I, and L due to small amounts of $\text{H}[\text{SbF}_4(\text{SO}_3\text{F})_2]$ are present. The expected peaks F and G for this species are hidden by other peaks. The six lines N, O resulting from $\text{H}[\text{SbF}_3(\text{SO}_3\text{F})_3]$ are clearly recognizable. Two new lines, Q and R, appear in this spectrum and they may be assigned to the species produced in solution by $\text{SbF}_2(\text{SO}_3\text{F})_3$. We assume that *cis*- and *trans*- $\text{SbF}_2(\text{SO}_3\text{F})_4^-$ are formed and that they give rise to the lines Q and R. No lines that can be attributed to dimeric forms of $\text{SbF}_3(\text{SO}_3\text{F})_3$ were observed, although it is probable that dimers and perhaps higher polymers are present in these solutions. Recall that the conductivity data on solutions of $\text{SbF}_5\text{-}3\text{SO}_3$ could be satisfactorily explained by postulating the presence of dimers. Although the mole ratio of sulfur trioxide to antimony pentafluoride is 3.2:1, spectrum c shows the presence not only of $\text{H}[\text{SbF}_2(\text{SO}_3\text{F})_4]$ but also of $\text{H}[\text{SbF}_3(\text{SO}_3\text{F})_3]$ and even some $\text{H}[\text{SbF}_4(\text{SO}_3\text{F})_2]$. It seems likely therefore that in this solution and the

(7) J. A. Pople, W. G. Schneider, and H. J. Bernstein, "High Resolution Nuclear Magnetic Resonance," McGraw-Hill Book Co., New York, N. Y., 1959, p. 127.

others studied free SO_3 is present from the dissociation reactions.

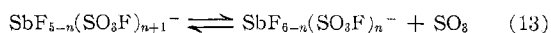

The fluorine-on-sulfur region of the spectrum for solutions of $\text{SbF}_4(\text{SO}_3\text{F})$ and $\text{SbF}_5\text{-SO}_3$ mixtures is rather complicated and consequently a detailed interpretation is difficult; however, some tentative assignments can be made. Figure 7 shows the effect, in this region of the spectrum, of adding SO_3 to a solution of SbF_5 . The largest peak in each spectrum is due to the solvent. Peaks A and B are observed in solutions of SbF_5 alone (Figure 6) and are assigned to the fluorosulfate groups in $\text{SbF}_5\text{SO}_3\text{F}^-$ and $(\text{SbF}_5)_2\text{SO}_3\text{F}^-$, respectively. These peaks are gradually replaced by peak Q as the molar ratio SO_3/SbF_5 approaches unity. The latter peak is therefore assigned to the fluorosulfate groups in $\text{SbF}_4(\text{SO}_3\text{F})_2^-$. As expected the spectrum (e) of a solution of $\text{SbF}_4(\text{SO}_3\text{F})$ is essentially the same as d, $\text{SO}_3/\text{SbF}_5 = 0.9$. The effect of dilution on the spectrum of $\text{SbF}_4\text{SO}_3\text{F}$ may be seen by comparing spectra e and f. On dilution peaks R and S decrease in intensity relative to peak T, and since dilution should cause the breakdown of dimers into monomers it seems probable that R and S are due to bridging and terminal fluorosulfates, respectively, in $(\text{SbF}_4\text{SO}_3\text{F})_2\text{SO}_3\text{F}^-$ and T is due to fluorosulfates in $\text{SbF}_4(\text{SO}_3\text{F})_2^-$. It was previously deduced that Q is due to fluorosulfates in $\text{SbF}_4(\text{SO}_3\text{F})_2^-$; the conclusion, therefore, is that Q is due to *cis*- $\text{SbF}_4(\text{SO}_3\text{F})_2^-$ and T is due to *trans*- $\text{SbF}_4(\text{SO}_3\text{F})_2^-$. The small peaks V and W could possibly be due to bridging and nonbridging fluorosulfates.

The effect on the fluorine-on-sulfur n.m.r. spectrum of increasing the mole ratio SO_3/SbF_5 to 1.8:1 is seen in g. Peak U gains in intensity with respect to the other peaks, suggesting the assignment of U to fluorosulfates in the species $\text{SbF}_3(\text{SO}_3\text{F})_3^-$. Further increase in the SO_3/SbF_5 ratio of 3.2 results in little change in the fluorine-on-sulfur spectrum (h). It is possible that lines appearing to low field of U are due to the species $\text{SbF}_2(\text{SO}_3\text{F})_4^-$ and $[\text{SbF}_3(\text{SO}_3\text{F})_3]_2\text{SO}_3\text{F}^-$.

The direct reaction between SbF_5 and SO_3 has been used by Hayek and Koller for the preparation of disulfuryl fluoride.⁸ In some of the concentrated solutions of SbF_5 and SO_3 in fluorosulfuric acid, small peaks due to small amounts of polysulfuryl fluorides were observed. These peaks were identified by adding small amounts of the pure compounds to the solution.⁹

Cryoscopic Measurements.—The results of cryoscopic measurements on solutions of SbF_5 , $\text{SbF}_4(\text{SO}_3\text{F})$, and $\text{SbF}_4(\text{SO}_3\text{F})\text{-SO}_3$ mixtures are given in Table IV and Figure 8. The freezing point curves for SbF_5 and $\text{SbF}_4(\text{SO}_3\text{F})$ are both somewhat surprisingly identical within experimental error with that expected for a nonelectrolyte (A).³ Freezing point curves calculated for the acid $\text{HSbF}_5(\text{SO}_3\text{F})$ with $K_4 = 3.7 \times 10^{-3}$ and $K_5 = 0$ (C), and also for $K_4 = 3.7 \times 10^{-3}$ and $K_5 = 7 \times 10^{-3}$ (B), are also shown in Figure 8, and the ex-

(8) E. Hayek and W. Koller, *Monatsh.*, **82**, 942 (1951).

(9) R. J. Gillespie, J. V. Oubridge, and E. A. Robinson, *Proc. Chem. Soc.*, 428 (1961).

TABLE IV

FREEZING POINT DEPRESSIONS			
10^3m SbF_5	θ , deg.	10^3m $\text{SbF}_4(\text{SO}_3\text{F})$	θ , deg.
3.334	0.131	2.72	0.108
6.850	0.270	6.03	0.223
9.601	0.394	8.23	0.316
10.46	0.424	12.13	0.451
18.54	0.746	15.22	0.620
26.87	1.096		
10^3m $\text{SbF}_4(\text{SO}_3\text{F})$	10^3m SO_3	θ , deg.	
4.15	0.000	0.155	
4.15	3.49	0.236	
4.15	10.4	0.434	
4.15	14.1	0.551	

Interpolated Values, $10^3m = 4.15$

	θ , deg.	ν
SbF_5	0.160	1.0
$\text{SbF}_4(\text{SO}_3\text{F})$	0.160	1.0
$\text{SbF}_3(\text{SO}_3\text{F})_2$	0.258	1.6
$\text{SbF}_2(\text{SO}_3\text{F})_3$	0.365	2.3
$\text{SbF}(\text{SO}_3\text{F})_4$	0.500	3.1

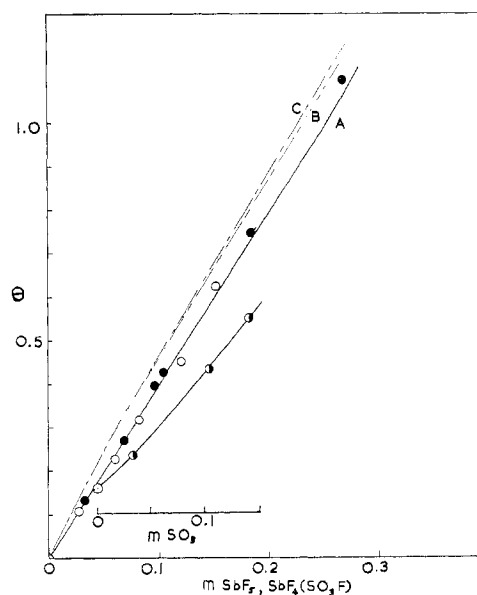
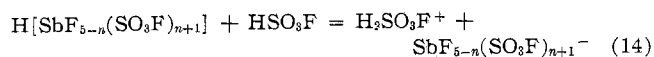

Figure 8.—Freezing points of solutions of SbF_5 , $\text{SbF}_4(\text{SO}_3\text{F})$, and $\text{SbF}_4(\text{SO}_3\text{F})\text{-SO}_3$ mixtures: ●, SbF_5 ; ○, $\text{SbF}_4(\text{SO}_3\text{F})$; ○, $\text{SbF}_4(\text{SO}_3\text{F})\text{-SO}_3$; A, theoretical curve for a nonelectrolyte; B and C, calculated curves (see text).

perimental points for SbF_5 , although they have a fair amount of scatter, do not agree with either of these calculated curves. As $\text{H}[\text{SbF}_4(\text{SO}_3\text{F})_2]$ is a stronger acid than $\text{H}[\text{SbF}_5(\text{SO}_3\text{F})]$ it would be expected to give a larger freezing-point depression than $\text{H}[\text{SbF}_5(\text{SO}_3\text{F})]$, so in this case the disagreement between the experimental values of the freezing point and the expected curve is even greater. It can only be concluded either that these two acids are much weaker at -89° than they are at 25° or that they are more highly polymerized. The latter seems the more likely explanation, particularly as this is also indicated by the n.m.r. results, and one must then further conclude that the extent of polymerization just balances the amount of

ionization so that they both produce an average of only one particle per molecule of SbF_5 or $\text{SbF}_4\text{SO}_3\text{F}$.

Table IV and Figure 8 also give the results of an experiment in which SO_3 was added to a 0.0415 *m* solution of $\text{SbF}_4(\text{SO}_3\text{F})$ and the freezing point measured. Freezing points interpolated for the compositions $\text{SbF}_3(\text{SO}_3\text{F})_2$, $\text{SbF}_2(\text{SO}_3\text{F})_3$, and $\text{SbF}(\text{SO}_3\text{F})_4$ gave values of $\nu = 1.6$, 2.3, and 3.1, respectively, where ν is the number of moles of particles produced in solution by one mole of solute. Complete ionization of any of these acids would give $\nu = 2$



Thus the observed value of $\nu = 1.6$ for $\text{H}[\text{SbF}_3(\text{SO}_3\text{F})_2]$ is consistent with the conclusion from conductometric studies that it is not a strong acid. The observed value of $\nu = 2.3$ for $\text{H}[\text{SbF}_2(\text{SO}_3\text{F})_3]$ indicates that it is probably a strong acid and must be in equilibrium with an appreciable amount of free SO_3

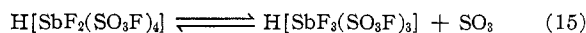

but because polymers are also undoubtedly present it is not possible to interpret the ν value quantitatively. Finally the value of $\nu = 3.1$ indicates complete dissociation of the acid $\text{H}[\text{SbF}(\text{SO}_3\text{F})_4]$ to $\text{H}[\text{SbF}_2(\text{SO}_3\text{F})_3]$ and SO_3 , which is consistent with the previous conclusion from the conductometric and n.m.r. studies that the higher fluorosulfates $\text{SbF}(\text{SO}_3\text{F})_4$ and $\text{Sb}(\text{SO}_3\text{F})_5$ are extensively if not completely dissociated into sulfur trioxide and lower fluorosulfates.

Acknowledgments.—We thank the Defence Research Board of Canada, the Directorate of Chemical Sciences of the United States Air Force Office of Scientific Research, and the Petroleum Research Fund of the American Chemical Society for generous financial assistance. We also thank the Ontario Research Foundation for the award of a fellowship (to R. C. T.) and the East Ham Education Authority, London, England, for the award of a scholarship (to J. B.).

CONTRIBUTION FROM THE DEPARTMENT OF CHEMISTRY,
UNIVERSITY OF CINCINNATI, CINCINNATI 21, OHIO

The Preparation and Properties of Some Tetracoordinate Boron Compounds. The Pseudo-Metal Ion Concept

BY L. H. TOPORCER, R. E. DESSY,¹ AND S. I. E. GREEN

Received March 30, 1965

The infrared, ultraviolet, H^1 and B^{11} nuclear magnetic resonance spectra, and polarographic behavior of a series of R_2B complexes possessing tetrahedral geometry indicate that they and similar derivatives can serve as excellent models with which to study chelate characteristics. The R_2B moiety functions as a pseudo-metal ion or atom which permits alteration of total and effective charge without variation in size of the chelate ring and permits placement and surveying of probes to study the electron distribution in the chelates.

Introduction

In a previous publication² the kinetics of the cleavage of triethylborane with weak acids were studied, and a mechanism emphasizing the essential prior coordination was proposed which was consistent with available data. The present paper describes a series

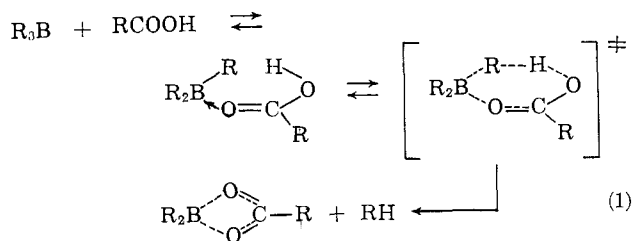

of investigations on the products of this reaction, and related processes, which yield compounds involving four-coordinate boron.

Experimental

All melting points were uncorrected and obtained on a Fisher-Johns melting point apparatus. The molecular weight determinations were obtained from a Mechrolab Model 301 osmometer at approximately 0.1 *M* concentrations. A Baird-Atomic Model KM-1 infrared spectrophotometer was used to obtain the infrared spectra, and a Varian A-60 n.m.r. spectrometer was used for the proton n.m.r. spectra. The B^{11} spectra were obtained on a Varian high-resolution spectrometer at 19.3 Mc. The ultraviolet spectra were obtained on a Cary Model 11 recording spectrophotometer. The analyses were done by Galbraith Laboratories, Inc., Knoxville, Tenn.

Reagents.—Triethylborane was used as obtained from Stauffer Chemical Co., Anderson Chemical Division. Gas chromatographic analysis indicated one major component with a trace of a minor one. The following compounds were obtained from Matheson Coleman and Bell and their method of purification is indicated: 2,4-pentanedione (distilled, b.p. 136°), ethyl acetoacetate [b.p. 66–68° (11 mm.), used as obtained], 1,3-diphenyl-1,3-propanedione (recrystallized from ether), boron trifluoride ethyl ether complex (distilled, b.p. 124°), and 2(1H)-pyridone (recrystallized from benzene, m.p. 106–107°). The 8-quinolinol was Eastman White Label material. Phenylacetylene was used as purchased from Columbia Chemicals Co. Hexafluoroacetylacetone was obtained from K and K laboratories.

(1) Alfred P. Sloan Fellow.

(2) L. H. Toporcer, R. E. Dessy, and S. I. E. Green, *J. Am. Chem. Soc.*, **87**, 1236 (1965).